



# Proximity Hand Detection & Switch Activation

## The LEDs on the front is used for 2 different purposes in this circuit.

The LED illuminates when the button is pressed and indicates that the circuit is active.

If the button is pressed again, the LED goes out and the circuit is disabled. Button connections are transmitted directly to the out put via the circuit. These connections are in dry contact form.

The circuit board does not ignite or extinguish itself. The LEDs' illumination or extinguishing signal is sent by the same processor unit which receives the button signal.

It is the Inncom device that processes the signals in the project.

Figure-1 shows dry contact connections to the Inncom device.

All those described up to this point is the normal key operation.

## There is a processor on our circuit board.

While the LEDs in standard products are driven by Inncom, the LED lighting signals on our circuit are taken by the processor. Therefore, inncom output current value is in significant. Figure-2 shows the relationship of the button and led.

Figure-3 shows the led Off state



Figure-3

Dry contact momentary switch outputs

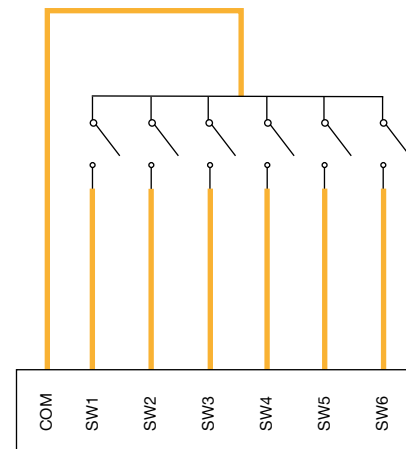

Figure-1

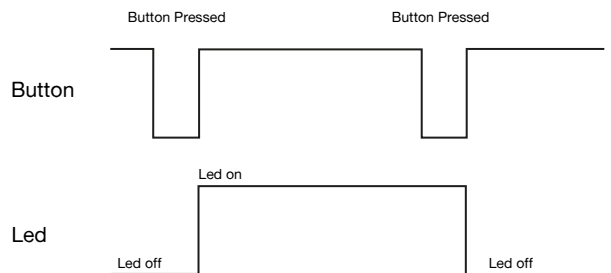

Figure-2

Figure-4 shows the led On state.

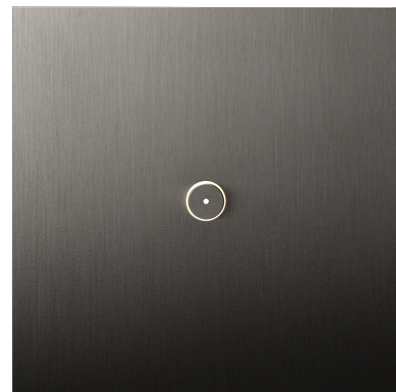

Figure-4

# Proximity Hand Detection & Switch Activation

**We have already mentioned that leds will be used for two different purposes. The second purpose of the LED is to show the approach signal of the human hand.**

In a completely dark room the user will have difficulty seeing the buttons. The front surface of our face plate also acts as a proximity sensor and detects a human hand from a distance of approximately 20cm. The face plate can make the detection from any direction.

The LED illuminates at the level of 30% when the human hand is detected and the user can easily see the location of the buttons. 30% illumination value is used as backlighting. Figure-5 shows the human hand is detected.

If the user does not reach out and press the button, the LED will go off again after a certain time.

If the user continues to approach and presses the button, the button signal goes to the Inncom device and the led is illuminated according to the input signal. If the LED is lit, the status does not change during approach (Figure-6). Figure-7 shows the theory of operation.

The processor in the circuit is programmed to use the same led proximity detection and status indicator.

Hand Detected 30% illuminated

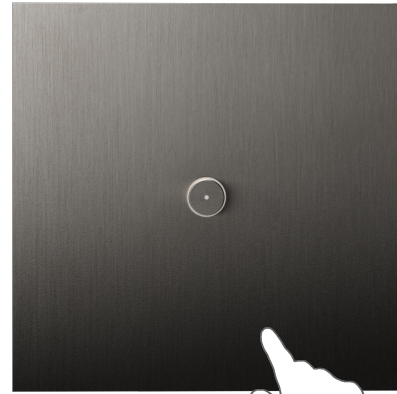

Figure-5

Approaching while the led is lit

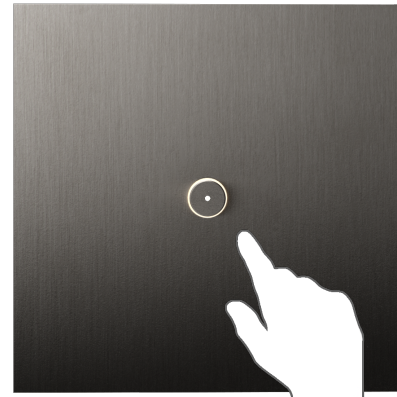

Figure-6

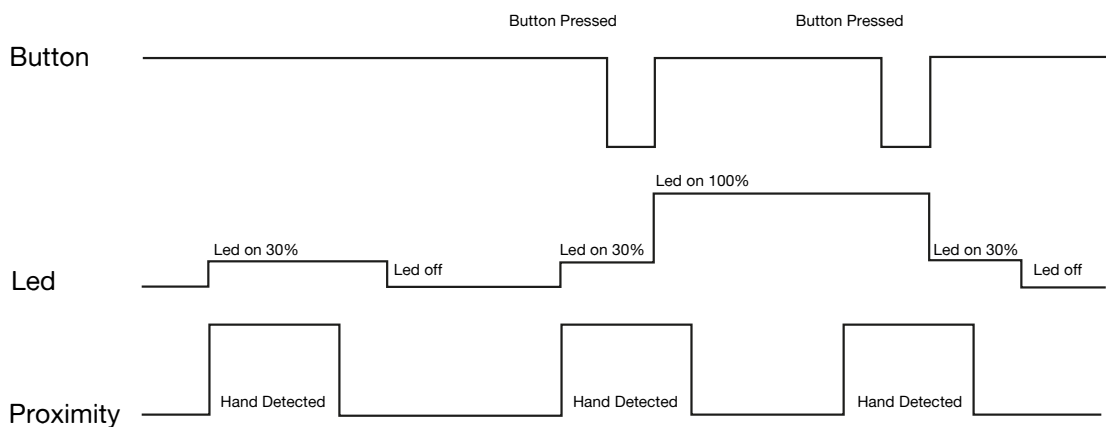

Figure-7

# Proximity Hand Detection & Switch Activation

## Maximum 6 buttons and LEDs can be found on the circuit.

All of these LEDs and buttons work as described. In the case of products with multiple buttons and LEDs, all leds act as backlights during approach. Figure-8 shows LED connections to the Inncom device.

## There is a lux sensor input on the circuit.

30% illumination for backlighting is turned on or off depending on the signal from this input. The contractor can apply 12 volts or 0 volts directly to this input. This signal is detected by the processor on the circuit. The contractor can select how the signal from the Lux sensor should be handled by the circuit. Figure 8 shows the lux sensor connection. The product operates with 12 volt direct current.



6 buttons face plate

Power, Lux sensor, LED/Backlight inputs

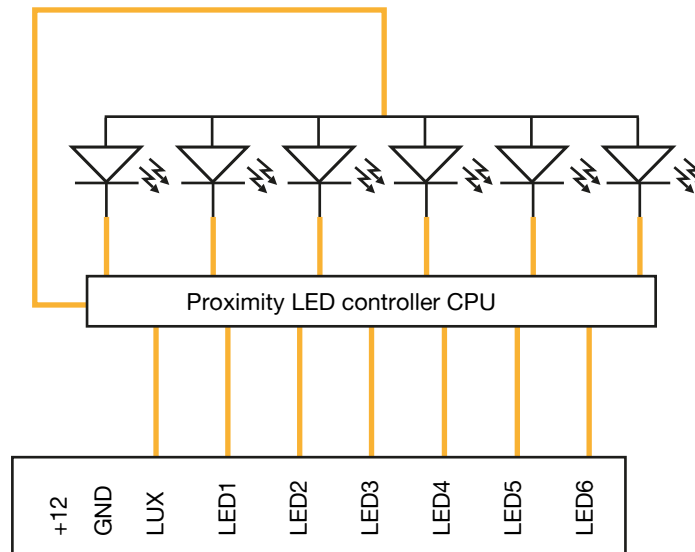

Figure-8